



## RAUVOLET METALLIC-LINE

### MONTÁŽNÍ NÁVOD



# Metallic-line 20 mm/25 mm

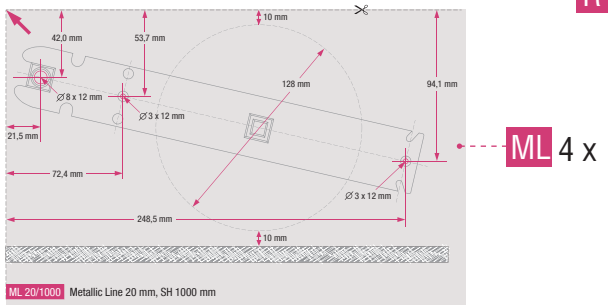
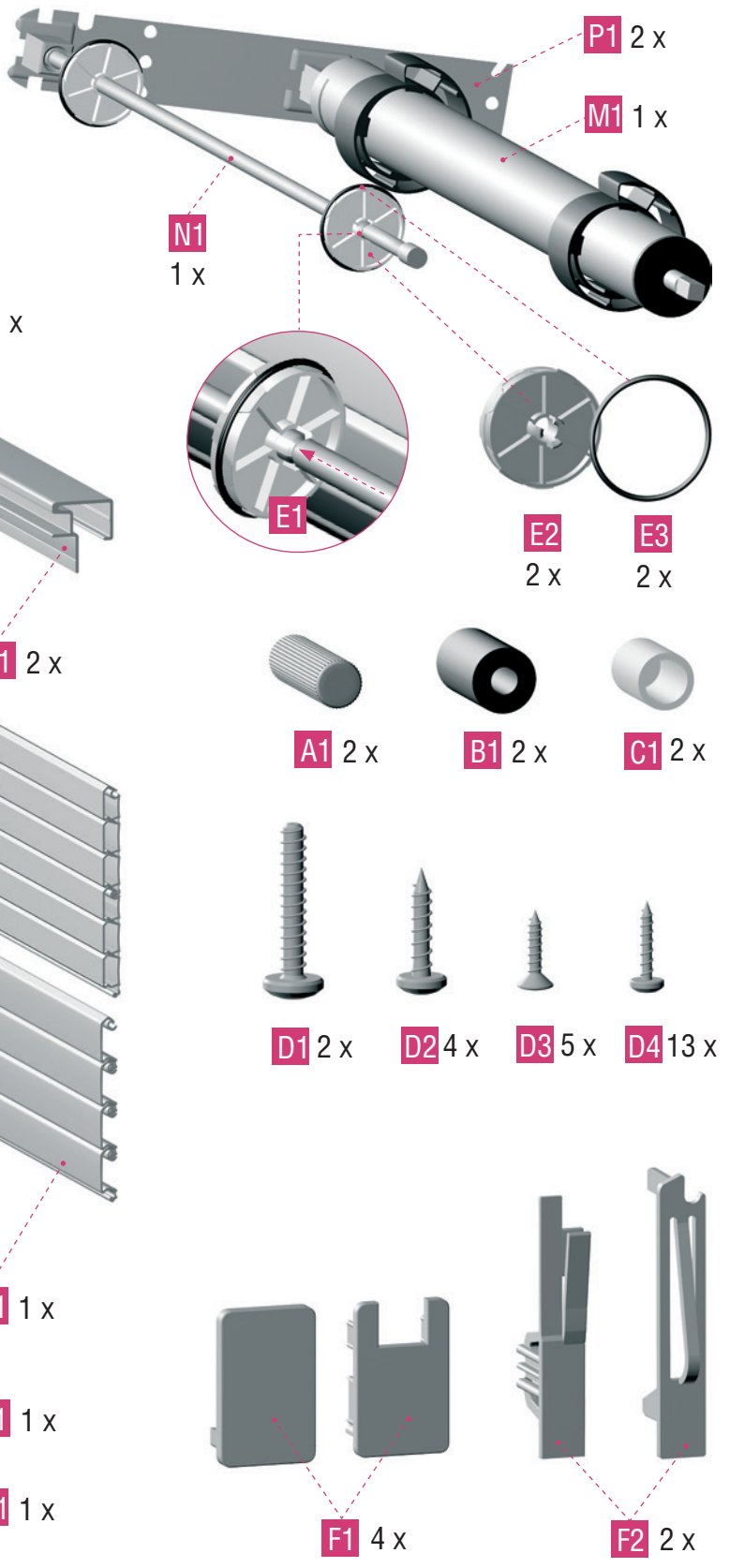
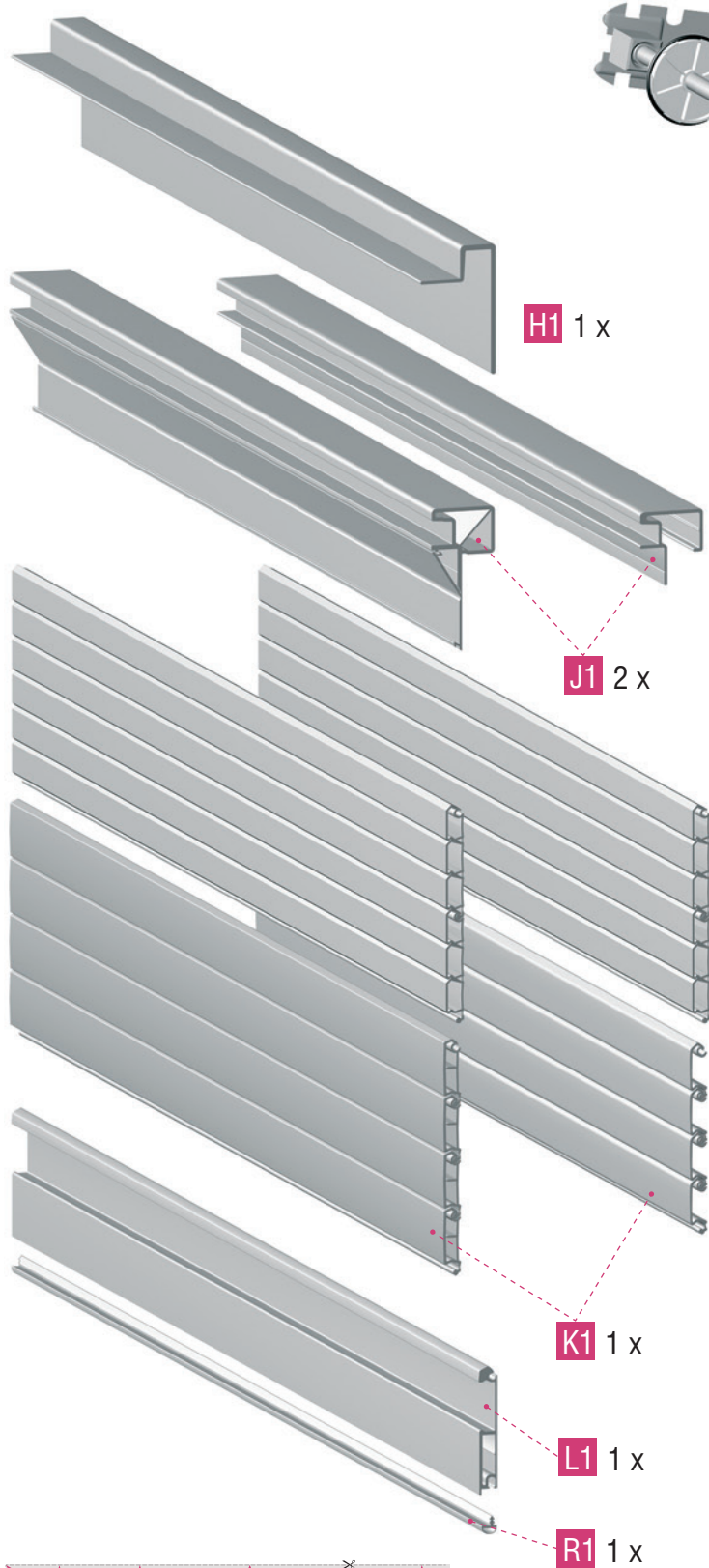

ML 20/1000 Metallic Line 20 mm, SH 1000 mm

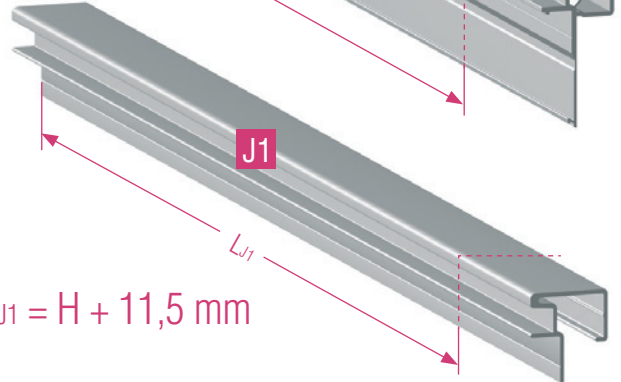
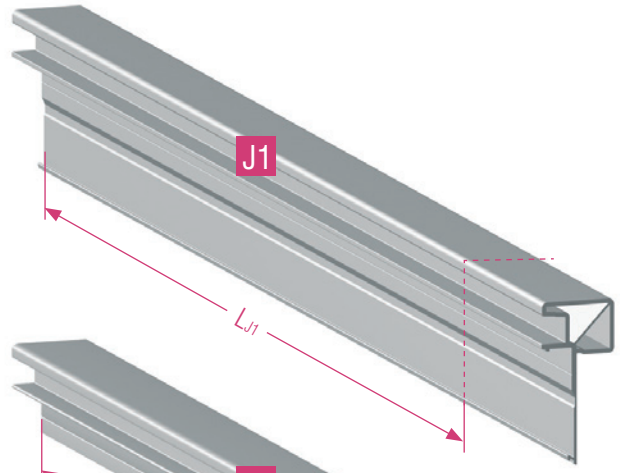
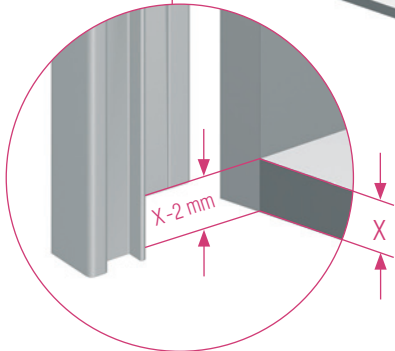
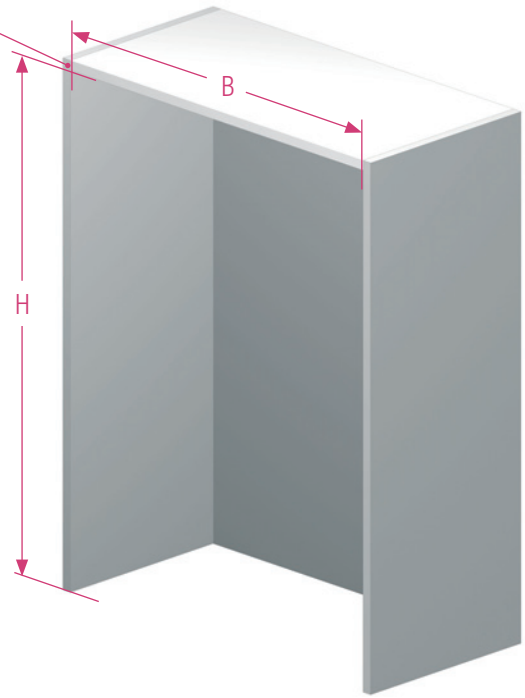
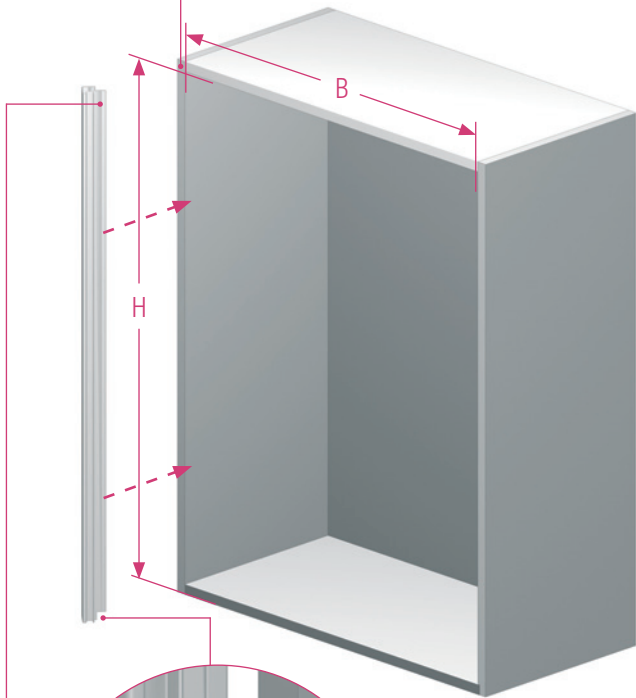
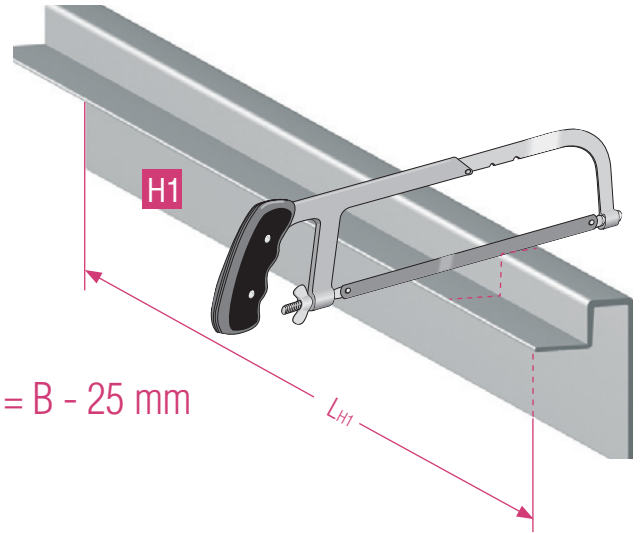
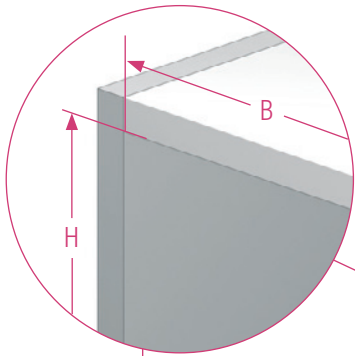

**POZOR!** Ve standardních sotech již připraveno. Tato úprava se provádí pouze u atypických setů.

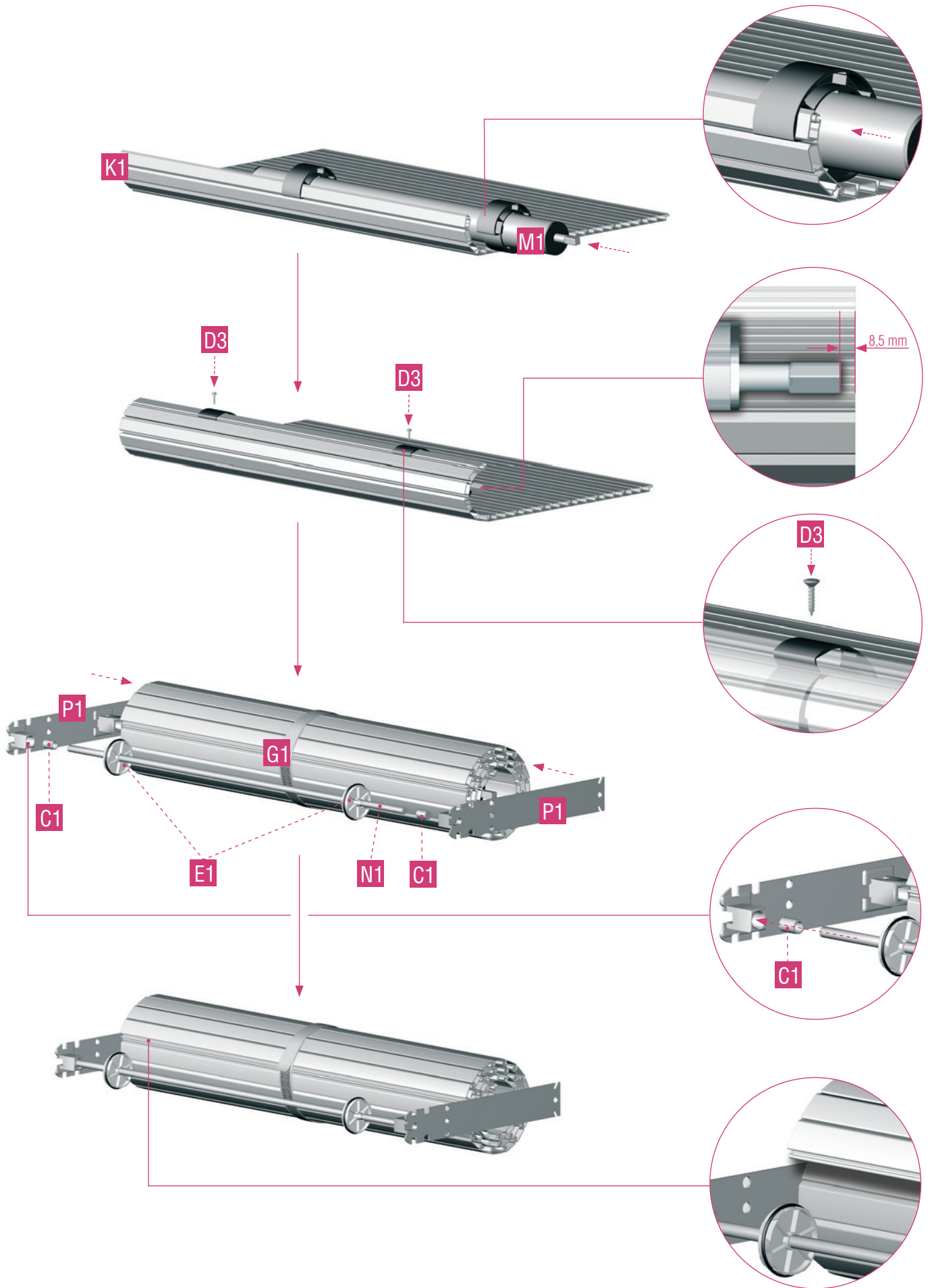

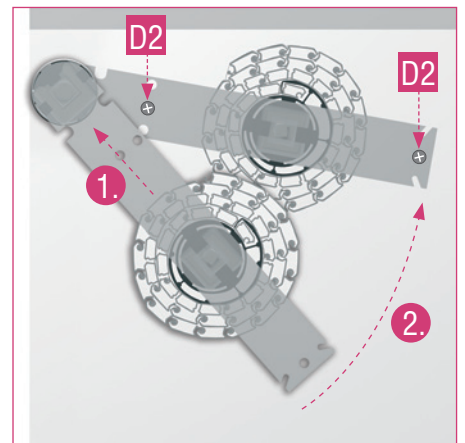
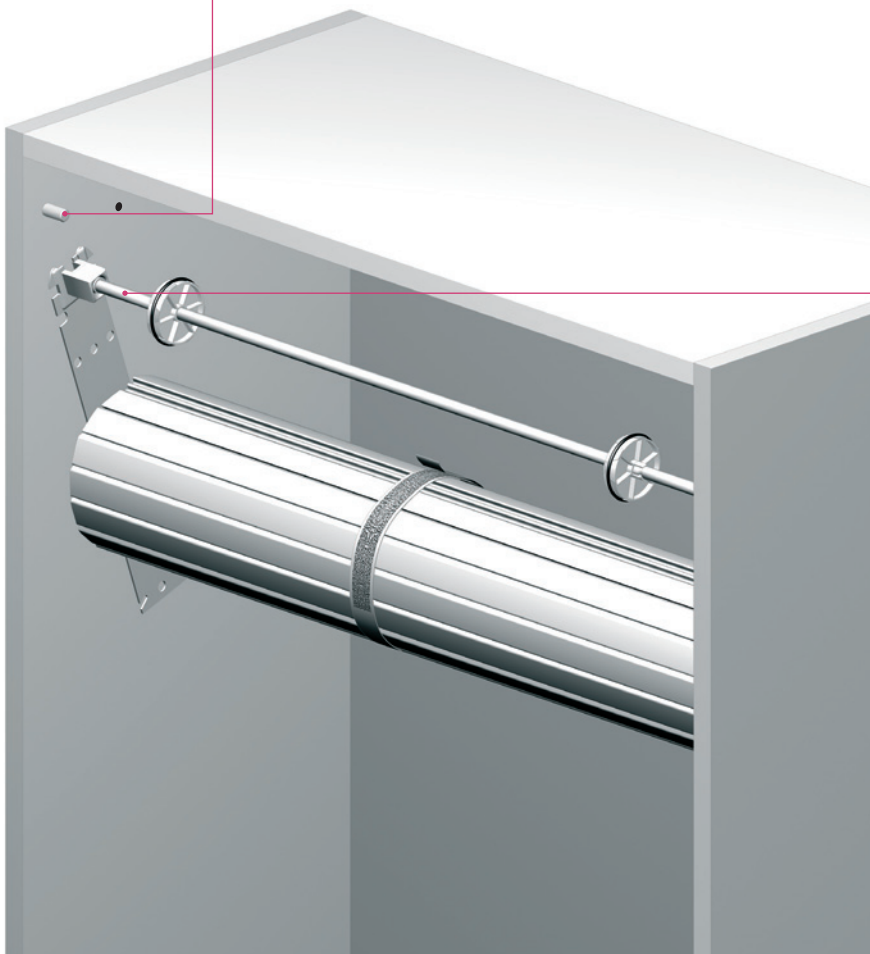
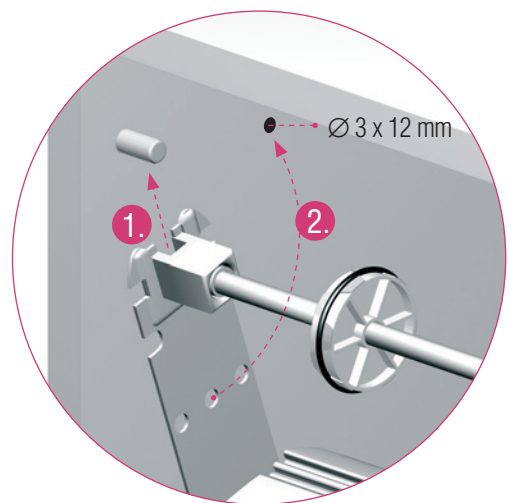
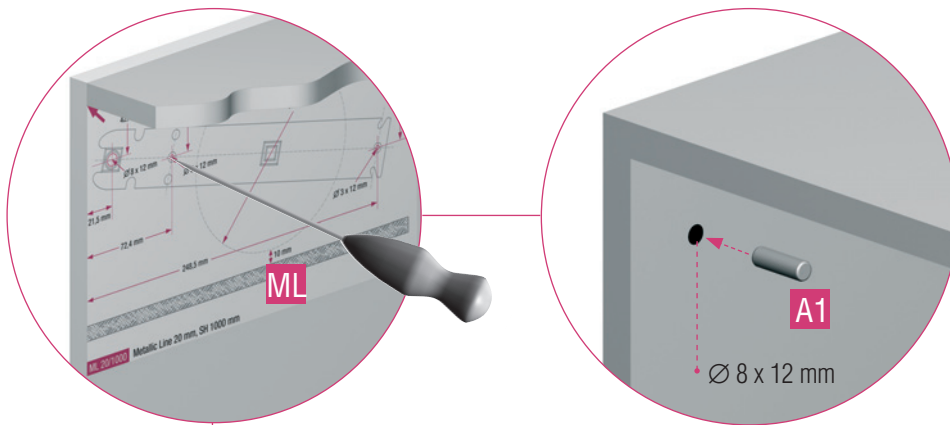

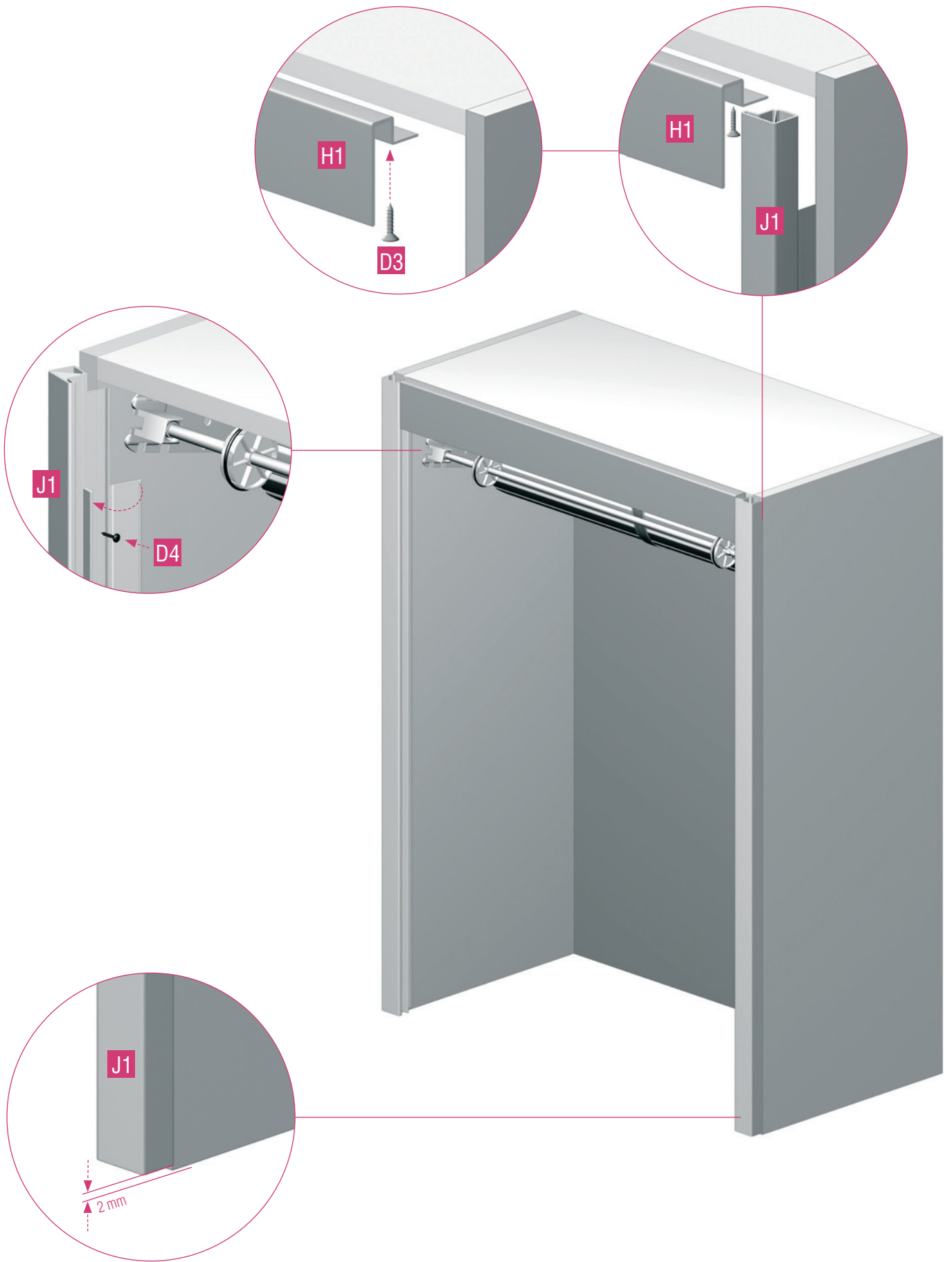

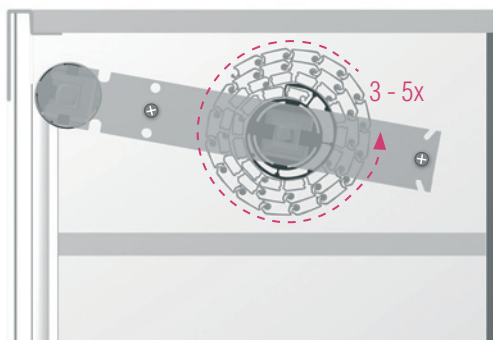

SH 600 - 1000 mm



SH 1000 - 1500 mm

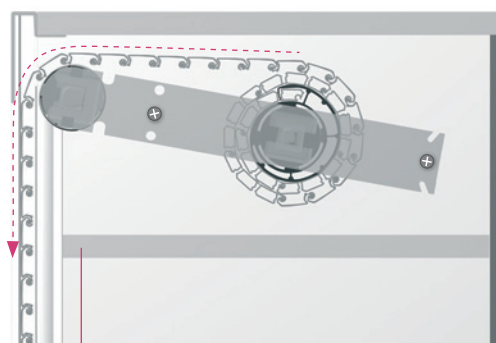
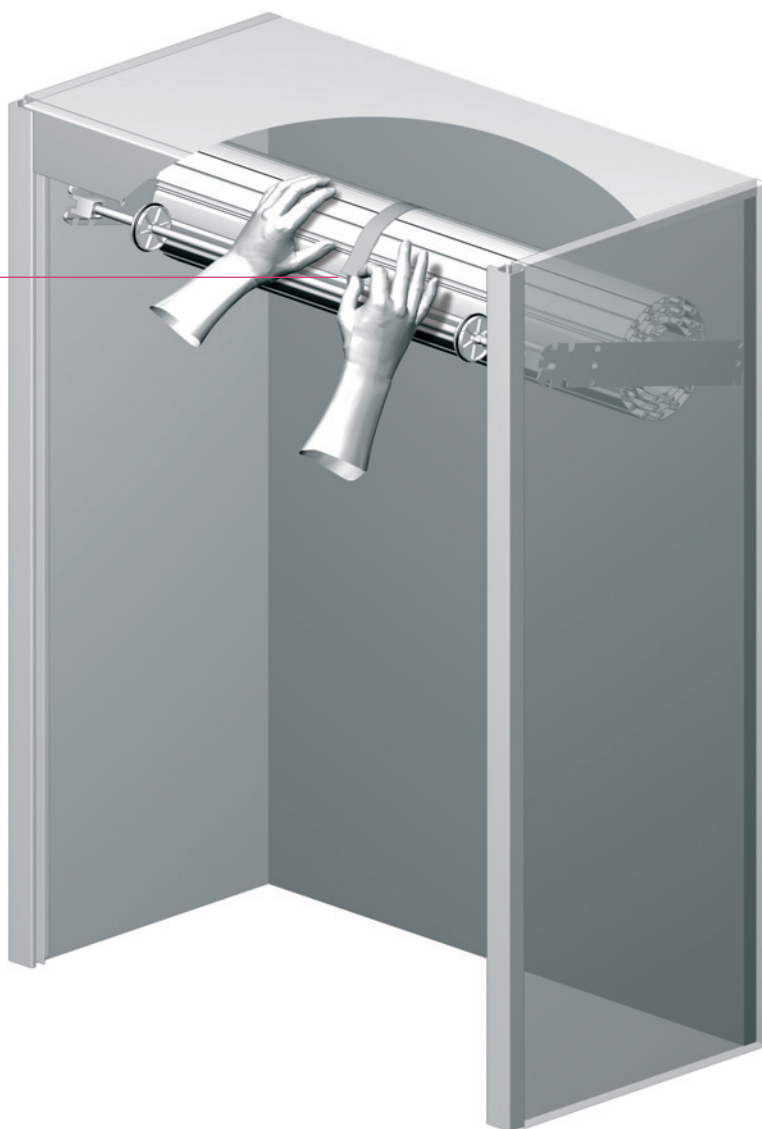
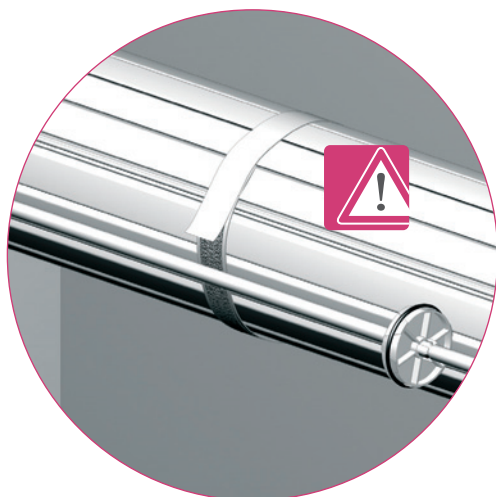
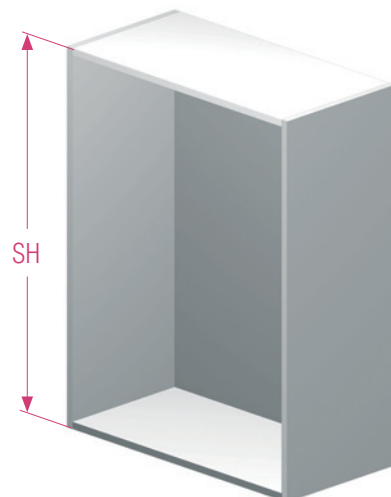

Koncovou lištu je nutno zastavit pomocí zarážky B1 o falešnou půdu, příčník nebo jiný doraz.



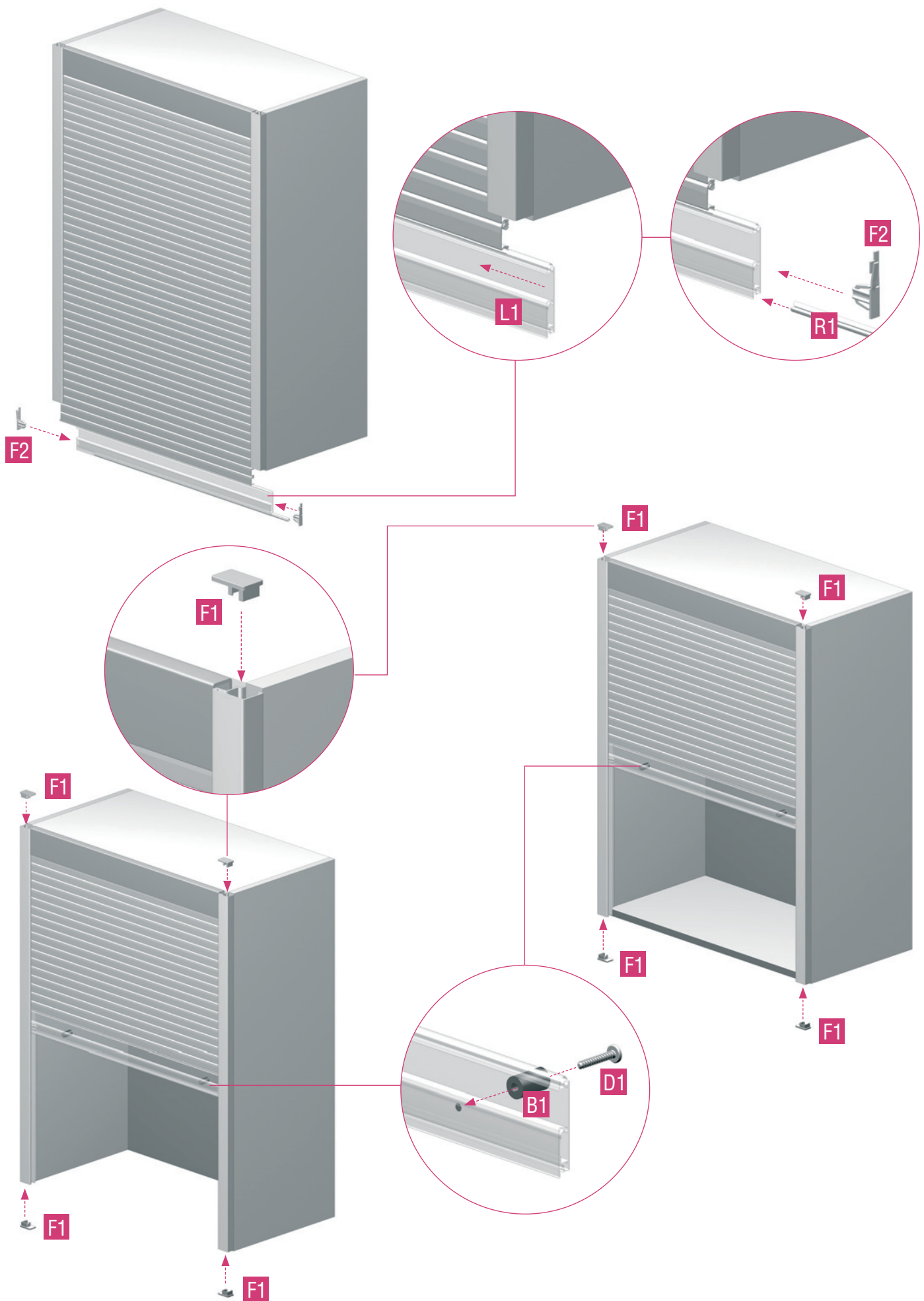

---

# ATYPICKÉ ROLETOVÉ SETY METALLIC-LINE 20 MM/25 MM

## POKYNY PRO PŘÍPRAVU KOMPONENTŮ

### Výpočet délky profilů:

1. Roletový profil Metallic-line 20 mm/25 mm:
  - bez profilových kluzných kolíků: vnitřní šířka – 11 mm
  - při použití profilových kluzných kolíků: vnitřní šířka – 14 mm (doporučeno)
2. Koncová lišta ALU Kombi: vnitřní šířka – 15 mm
3. Krycí lišta s přesahem ALU: vnitřní šířka – 25 mm
4. Středová úchyťová lišta C3 ALU:
  - bez kluzných kolíků: vnitřní šířka – 11 mm
  - při použití kluzných kolíků: vnitřní šířka – 14 mm (doporučeno)
5. Vodicí lišta ALU 29 mm: viz str. 4

**Pokyny pro montáž vyvažovací mechaniky C3:** viz přiložené montážní šablony ML 25/1000, popř. ML 25/1500

**POZOR!** Vnitřní hloubka korpusu musí činit min. 290 mm!